

Patented Oct 23, 1923

1,471,437

UNITED STATES PATENT OFFICE.

HELEN WOOD, OF CLEVELAND, OHIO

PRIMARY EDUCATIONAL APPLIANCE

Applicat on filed November 16 1921 Serial No 515,688

To all whom it may concern

Be it known that I, HELEN WOOD, a citizen of the United States, residing at Cleveland, in the county of Cuyahoga and State of Ohio have invented certain new and useful Improvements in Primary Educational Appliances, of which the following is a specification

This invention relates to a primary educational appliance and has for its object the provision of a device of this character whereby the fundamental arithmetical operations may be objectively demonstrated to children, or primary pupils

It is an authentic fact that the immature, or undeveloped mind is more susceptible to material objects which present quantity, than it is to characters, such as figures, which have merely quantity significance therefore the fundamental principles of quantity calculations are readily grasped when demonstrated to a child by object lessons

The present invention provides for the development of quantity thinking by exercising the senses of sight and touch. It enables the child to readily conceive the relation of quantities by providing a material objective unit of a given size as a basis or elementary unit and a series of unitary objects of different sizes proportionate to the elementary unit. By proper arrangement of the unitary objects the pupil will appreciate each member as a unit having its individual relative size. It makes possible the combining of smaller units into a large unit whole in such a manner that the pupil conceives the construction of the larger unit. It enables the pupil to analyze each unit, from one to an indefinite greater number into its component units or parts. The use of the appliance also enables the primary or child pupil to understand what component unit remains when another component unit is removed from the larger unit whole and to readily see how a given larger unit whole may be resolved into its equal component units and to readily observe what part the smaller unit is of the larger unit whole of which it is one or more of the equal component parts. The appliance further provides for the elimination of hap-hazard guessing, or finger counting on the part of a child pupil

I have devised an appliance of simple construction for conveniently demonstrating or accomplishing these objects. An embodi-

ment of the said appliance is illustrated in the accompanying drawing which is made part of the specification, and to facilitate the understanding of the appliance I have employed similar reference characters to designate corresponding parts throughout the description and in said drawing

Fig 1 is a perspective view of a rack used as a support for numerous block holders and the blocks carried therein

Fig 2 illustrates a number of the block holders, and Fig 3 shows a variety of blocks which are employed

In the embodiment of the invention as illustrated 1 represents a support having a flat base element 1^a on which is mounted an upright rack which, for convenience is preferably inclined backward from the base upward. This rack provides a series of compartments, or parallel vertical channels 1^b equally spaced by division members 1^c. These channels are designed for the accommodation of a series of holder elements 2 of various lengths which may be made of light sheet metal of channel formation open at the top and closed at the bottom as shown at 2^a. The holders 2 provide carriers or retainers for blocks 3 of different sizes, as more fully set forth hereinafter

The blocks 3 are of uniform transverse dimensions preferably square but are of different lengths. An elementary unit block of a predetermined size being adopted the length of each and all the blocks employed is a certain proportion to the length of the elementary unit. For the purpose of clarifying the explanation assume one inch square as the elementary unit. The present embodiment provides a capacity of twenty four rack compartments of an equal height of say twenty four inches. In this instance a total of eighty seven blocks and twenty-four holders are used. The holders range in height from one inch to and including twenty four inches while the blocks are in series as follows—Twenty four 1 inch high, twelve 2 inches eight 3 inches six 4 inches, five 5 inches four 6 and four 7 inches high, three 8 and three 9 inches, two each 10 and 12 inches, and one each of 13, 14, 15, 16, 17 18 19, 20, 21, 22 23 and 24 inches in height

Referring to Fig 3 the dotted lines denote that block 3^b is three times as long as block 3^a and that block 3^c is eight times as long as block 3^a. The holders are likewise propor-

1,471,437

tioned, as shown in Fig 2, in sequence multiples of the elementary unit

The blocks 3 are adapted to fit in the holders 2, and are displayed by arranging the holders in the rack 1, as shown in Fig 1

The primary stage of instruction by means of the improved appliance includes the prevailing upon the child to arrange the blocks in the holders, or to build up take down, and compare various combinations. This is easily brought about as it is more or less amusing to the child. This amusement interests him so that it impresses on his mind the results of the different combinations and these results are object demonstrations of the fundamental arithmetical operations.

The following are examples of various operations:

(a) The pupil arranges a 3 inch block beside a 3 inch holder and then places a 2 inch and a 1 inch block in the holder. This shows him that the combined quantity on the 2 inch unit and the 1 inch unit is equal to the 3 inch unit, or that 2 and 1 equal 3.

(b) In an 8 inch holder the pupil places a 5 inch block and a 3 inch block beside it, then he removes the 3 inch block and he observes that the 5 inch block remains which denotes that a 3 inch unit taken from an 8 inch unit leaves a 5 inch unit, and that 5 and 3 equal 8.

(c) A two inch unit is placed in a 10 inch holder and the pupil fills the holder with other 2 inch units, he then sees that 5 of the 2 inch units completely fill the 10 inch holder, and therefore is made aware that 5 times 2 equals 10.

(d) Removing the 2 inch units which have been placed in the 10 inch holder and separating them, the pupil is made to understand that the 10 inches is made up of 5 equal units or 2 inch blocks, and that 10 may be divided into 5 twos.

(e) Beside a 3 inch block the pupil places three 1 inch blocks in a 3 inch holder and observes 3 as a unit whole, removing one of the three blocks he sees that he has taken $\frac{1}{3}$ of the whole unit, and by removing two of the blocks he has taken $\frac{2}{3}$ of the whole unit.

The above are but a few of the innumerable simple problems or primary arithmetical operations that may be objectively demonstrated by the arrangement of the blocks and holders. Various combinations may be exhibited in the rack where comparisons may be made, and the different operations explained by teachers to classes, or individual pupils.

While the present embodiment of the appliance provides for 24 holders, 87 blocks, and a supporting rack 24 units high and having 24 compartments it will be understood that these quantities are arbitrary that

the capacity of the appliance may be increased, or decreased, that the elementary unit block may be of different dimensions than that specified, with the multiple unit blocks dimensioned accordingly, and that there may be other changes, or diversions from the foregoing specification without departing from the spirit of the invention or the scope of the claims.

Having described my invention, what I claim and desire to secure by Letters Patent is:

1. In an educational appliance a series of blocks of uniform given dimensions which are used as elementary units and a series of blocks having transverse dimensions equal to those of the elementary units and having different length dimensions of increasing sequence multiples of the length dimension of an elementary unit block, the second series comprising groups of different lengths a determined number of blocks being twice the length of an elementary unit block a determined number being three times the length of an elementary block, and so on indefinitely in sequence there being a determined number of like blocks in each group and the length dimensions of the blocks in each group being a multiple of the length dimension of an elementary block, and a series of holders for the blocks, said holders being of different lengths corresponding to the lengths of the blocks in both the first, and second series.

2. In an educational appliance a series of blocks of uniform given dimensions which are used as elementary units and a series of blocks having transverse dimensions equal to those of the elementary units and having different length dimensions of increasing sequence multiples of the length dimension of an elementary unit block the second series comprising groups of different lengths a determined number of blocks being twice the length of an elementary unit block a determined number being three times the length of an elementary block, and so on indefinitely in sequence there being a determined number of like blocks in each group and the length dimensions of the blocks in each group being a multiple of the length dimension of an elementary unit block a series of holders for the blocks and holders being of different lengths corresponding to the lengths of the blocks in both the first and second series, and a supporting rack provided with a series of open compartments in which the holders are adapted to slide for displaying said holders and the blocks arranged therein.

In testimony whereof I affix my signature

H FLEN WOOD

Oct 23, 1923

1,471,437

H WOOD

PRIMARY EDUCATIONAL APPLIANCE

Filed Nov 16 1921

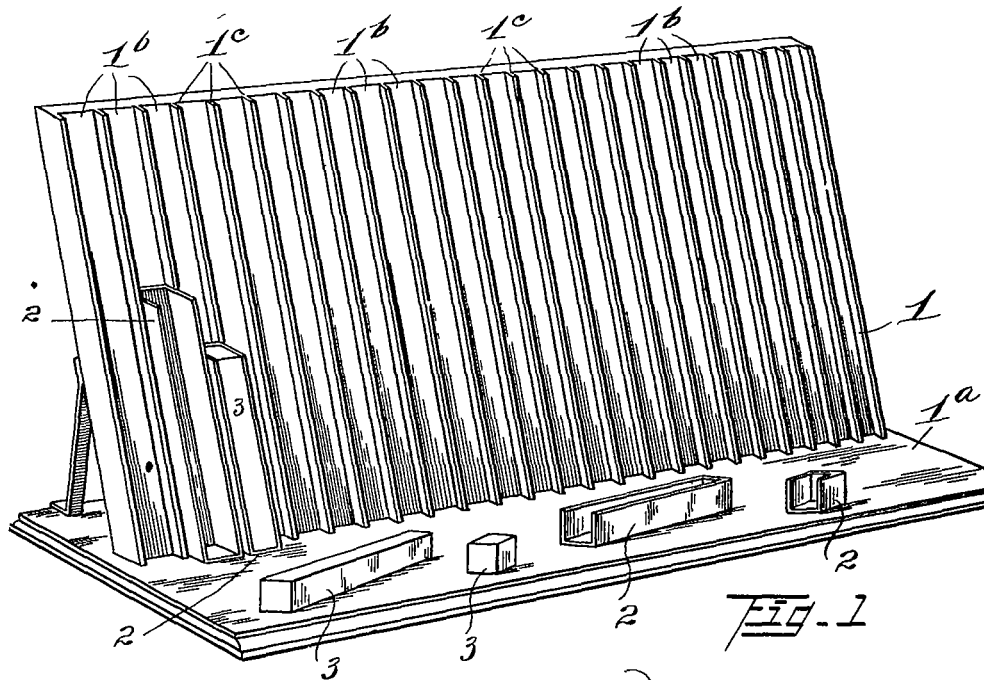

FIG. 1

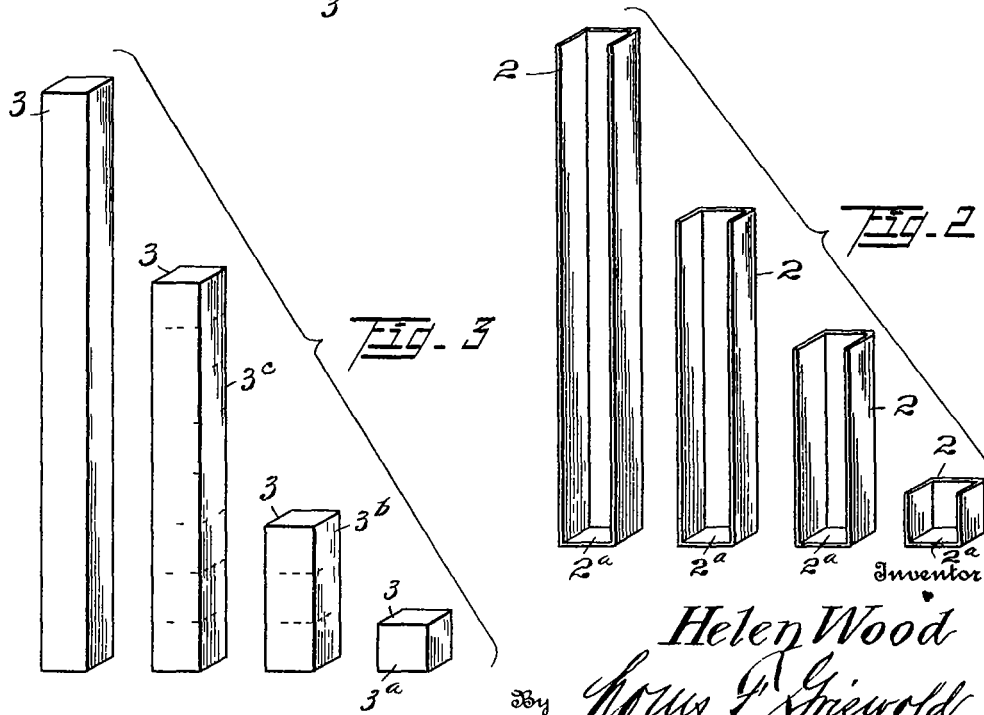

FIG. 3

FIG. 2

Inventor

Helen Wood
John F. Griewold

Attorney

UNITED STATES PATENT OFFICE.

ROY DAVID MITCHELL, OF SANDUSKY, OHIO

EDUCATIONAL DEVICE

No 832,871

Specification of Letters Patent

Patented Oct 9, 1906

Application filed December 2, 1905 Serial No 289,954

To all whom it may concern

Be it known that I ROY DAVID MITCHELL, a citizen of the United States, and a resident of Sandusky, in the county of Erie and State of Ohio, have invented a new and Improved Educational Device, of which the following is a full, clear, and exact description

The purpose of the invention is to provide a simple device to assist a teacher in instructing a class in mathematics, particularly in addition, which device will save the time of a teacher in dictating problems and the time of the students in writing them, it being possible for the teacher to quickly and accurately designate the boundaries of figures on a chart in columns, the figures within which columns are to be added, and for the students to locate and rule off the boundaries without injury to the chart

A further purpose of the invention is to provide a device of the character described which will be very simple, easily understood, and readily handled, and which can be conveniently held in the lap or placed flat upon a desk

The invention consists in the novel construction and combination of the several parts as will be hereinafter fully set forth and pointed out in the claims

Reference is to be had to the accompanying drawings, forming a part of this specification, in which similar characters of reference indicate corresponding parts in all the figures

Figure 1 is a plan view of the improved device Fig 2 is a longitudinal section taken practically on the line 2-2 of Fig 1 Fig 3 is a perspective view of one of the adjustable defining-arms employed, and Fig 4 is a longitudinal section through one of the slides

A represents a frame comprising a bottom member 10, a top member 11 and side members 12 and 13, and within this frame a chart B is located, held in place by a suitable back B', secured by clamps B² or their equivalents, as shown in Fig 2 This chart B is ruled in a series of columns, and each column contains a series of single figures arranged one below the other, the figures on the chart being in alignment both vertically and transversely

The figures in the columns of the body portion of the chart are promiscuously arranged, but at the upper edge of the chart adjacent to the inner edge of the upper member 11 of the frame a horizontal defining-

column 14 is produced divided into vertical columns corresponding to the body-columns on the chart and reading therewith In each space thus made in the defining-column 14 a figure is produced, and these figures read consecutively from 1" to any given figure, and the said defining-column 14 is duplicated at the bottom of the chart, the lower column being designated at 14^a At the left-hand side edge of the chart a vertical designating-column 15 is produced and at the right-hand edge of the chart a corresponding designating-column 15^a is located These columns are divided into spaces having figures reading from the top downward consecutively from 1' to any desired number

Parallel undercut grooves 16 and 17 are produced in the front face of the upper frame member 11, extending from end to end of said member, and parallel longitudinal undercut grooves 16^a and 17^a are produced in the outer face of the right-hand side member of the frame, and these latter grooves extend from the upper member 11 out through the bottom end of the said side member, as is illustrated in Fig 1 These grooves 16 and 17 16^a and 17^a are of like cross-sectional shape and they may be T-shaped in cross-section, but usually they are given a crescent shape (Shown in Fig 2) In connection with the said frame two defining arms or rulers C and C' extend from the upper portion of the frame to the lower portion thereof, and these defining-arms are preferably made of thin flat metal—for example steel—and the side edges of the arms are parallel and straight The body portions of these arms are brought as close as convenient to the outer face of the chart and the upper ends of said arms are curved upwardly and then carried over the outer face of the upper frame member 11, as shown at 18 in the drawings Each of the said arms or rulers C and C' is provided with a slide 19, secured to its under face at its upper end, the said slides having the same cross-sectional shape as the grooves 16 and 17 and 16^a and 17^a, and said slides for the rulers C and C' are made to enter and are adjustable one in the groove 16 and the other in the groove 17 For convenience in moving said arms each arm is provided with a button or its equivalent at its upper end In connection with the arms C and C' and crossing the said arms two transverse defining-arms D and D' are employed of the same construc-

tion as the arms C and C', but the slides of the arms D and D' have movement in the undercut grooves 16^a and 17^a of the frame

The free ends of the longitudinal slides C and C' extend nearly to the inner margin of the lower member 10 of the frame, and the inner ends of the transverse arms D and D' extend practically to the inner edge of the left-hand side member 12 of the frame. These arms C and C', D and D' may be plain but preferably the arms C and C' have a vertically-reading scale of figures in the vertical defining-columns 15 and 15^a, while the transverse arms D and D' have transversely-reading scales of figures thereon reading the same as the figures in the upper and lower defining-columns 14 and 14^a.

Each slide 19, as is illustrated in Fig. 4, is provided with a downwardly-bowed spring 19^a at its under surface, usually held in position by clips 19^b, carried down from the ends of the slides. By means of the said springs 19^a the arms carried by the slides are kept at right angles to the frame in which they work and are not easily moved or jarred from place when adjusted.

In the operation of this device, each pupil being provided with one of said devices and the teacher also with one, the teacher will set the longitudinal arms at predetermined figures in the upper and in the lower defining-columns and the transverse arms to certain figures in the longitudinal defining-columns 15 and 15^a, calling out these figures to the class. The students of the class will then make a corresponding adjustment of the said arms upon their charts, and the figures to be added are thus contained within the field bounded by the said arms. Thus an unlimited number of examples can be given out and indicated on the chart without mutilating the same and saving the time of dictating the figures and the time of writing down the figures. In order that the free ends of the defining arms or rules shall not be in the way of the user of the device, a guide-rod 21 is secured to the frame and is arched over the ends of the longitudinal arms C and C', and a similar rod 22 is arched over the free ends of the transverse arms D and D'.

I desire it to be understood that I do not confine myself to the location of the grooves in the frame, as they may be differently placed without departing from the spirit of the invention.

Having thus described my invention, I claim as new and desire to secure by Letters Patent—

1 In an educational device, a chart containing columns of figures, and defining-arms which extend over the chart and are mounted for independent sliding movement, sundry of them longitudinally and others transversely relatively to the said columns of figures.

2 In an educational device, a chart con-

taining columns of figures and defining-arms mounted to slide over the chart, transversely and longitudinally relatively to the columns of figures, said arms being in pairs but each arm being capable of independent movement, the arms of one pair crossing the arms of the other pair.

3 In an educational device, a frame, a chart within the said frame, containing columns of figures, and longitudinal and transverse defining-arms adjustably mounted in the said frame, the said arms extending over the said chart, the longitudinal arms from top to bottom and the transverse arms from side to side.

4 In an educational device, a frame the upper member whereof is provided with undercut grooves in its outer face and the side member with corresponding grooves, and transverse and longitudinal defining-arms, each arm being provided with a spring-controlled slide at one end and a knob at the same end, the slides of the longitudinal arms being adapted to enter the undercut grooves in the top member of the frame and the slides in the transverse arm to enter the undercut grooves in the side member of the frame.

5 In an educational device, a frame having undercut grooves in one of its transverse members and corresponding grooves in one of its side members, a chart held in the said frame, having upper and lower defining-columns reading in consecutive figures commencing with "1," and longitudinal marginal defining-columns likewise reading in consecutive figures commencing with "1," the body portion of the chart being provided with columns in which figures are promiscuously produced, longitudinal and transverse defining-arms, each defining-arm being provided with a slide at one end and a knob at the same end, the slides corresponding in cross-section to the cross-section of the said grooves, the slides of the longitudinal arms being adjustable in the transverse grooves and the slides of the transverse arms in the longitudinal grooves, the transverse arms extending from side to side of the chart and the longitudinal arms from top to bottom thereof, the transverse arms having a scale of figures produced thereon corresponding to the reading of figures in the upper and lower marginal columns and the longitudinal arms having a scale of figures produced thereon corresponding to the figures in the said marginal columns of the chart, and guards for the free ends of the said arms.

In testimony whereof I have signed my name to this specification in the presence of two subscribing witnesses.

ROY DAVID MITCHELL

Witnesses

I W BOOKMYER,
FRANK F LANGWELI

No 832,871

PATENTED OCT 9, 1906

R D MITCHELL
EDUCATIONAL DEVICE
APPLICATION FILED DEC 3 1905

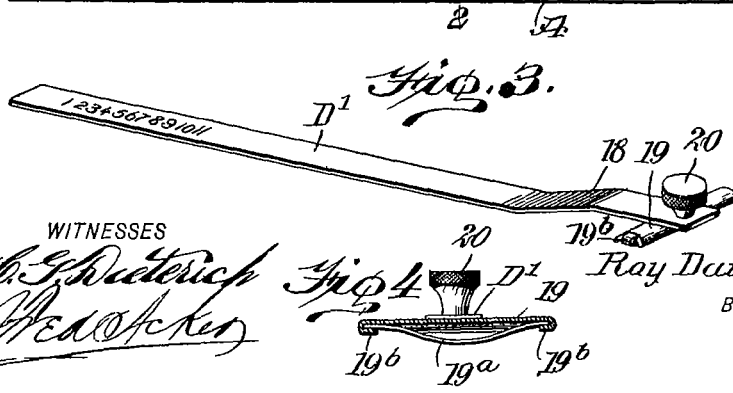
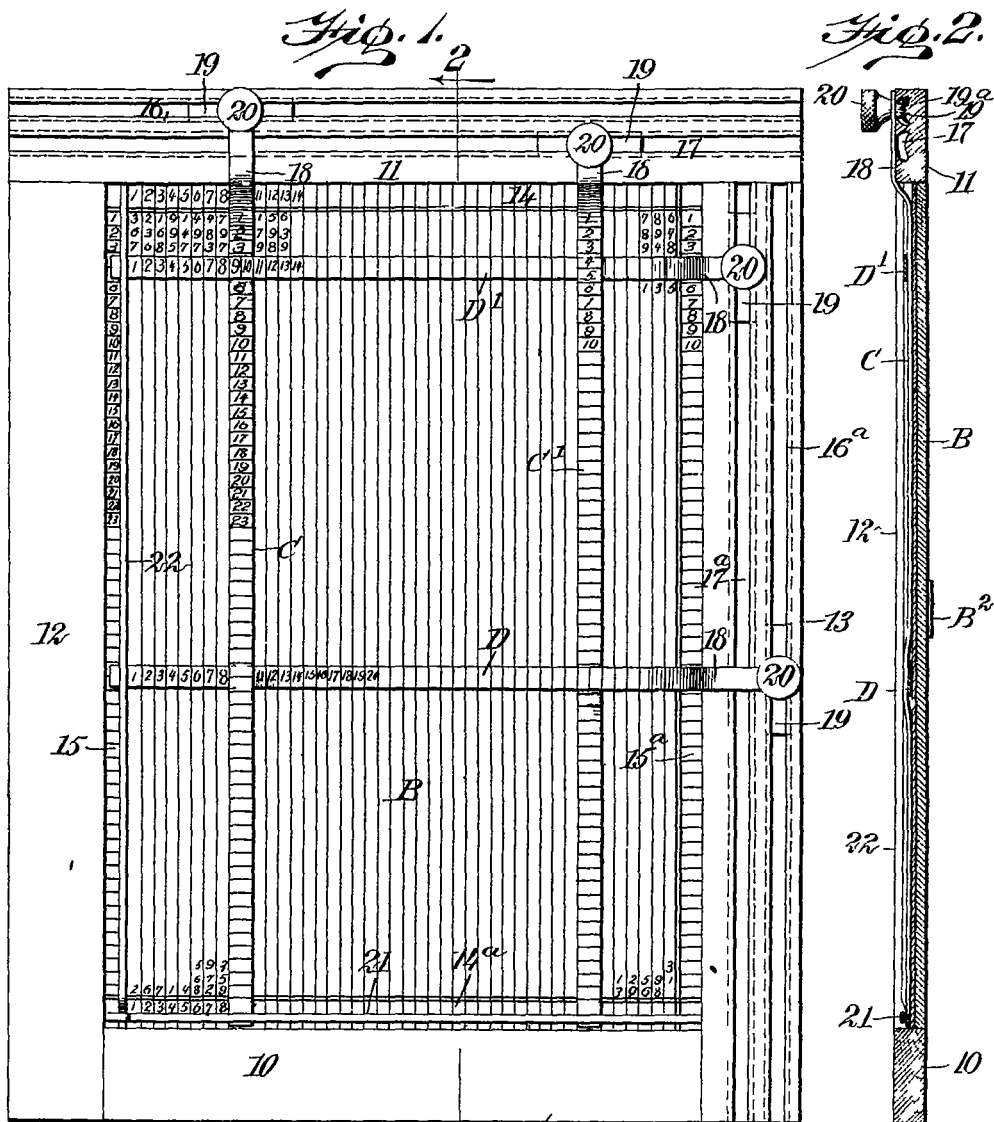

WITNESSES
H. S. Dierick
W. A. ...

INVENTOR
Ray David Mitchell
BY *Mumford*
ATTORNEYS